



www.unitrans.net.pl
biuro@unitrans.net.pl
tel./fax (032) 674 10 55/56

„UNITRANS”

ul. Dąbrowska 84
42-510 Wojkowie Kościelne

**SPECYFIKACJA I PARAMETRY
TECHNICZNE SPRZĘTU CIĘŻKIEGO**

ŻURAW RT 65S

GROVE Manufacturing Co

Udźwig 30 t

1. Wymiary

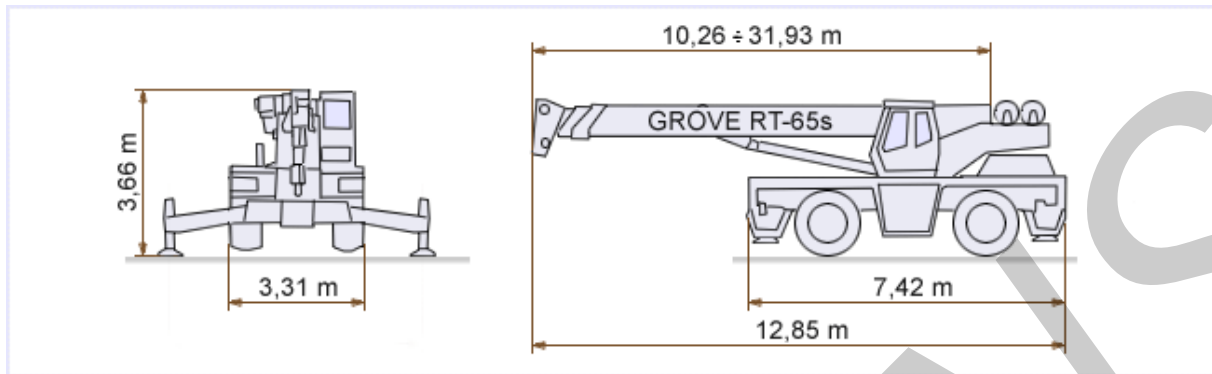

DIMENSIONAL CHART							
DIM	TIRE OPTIONS			BOOM OPTIONS		AUX. WINCH OPT.	
	29.5x25	26.5x25	21.0x25	10.1-24.4m	10.4-31.7	MOD30	MOD11
A	83.3cm	78.5cm	77.5cm				
B	250.2	247.8	245.1				
C	331.7	323.4	310.9				
D	331.5	331.5	331.5				
E	36.2	31.1		998.2 cm	1029.9		
F	53.3	48.3		2423.2 cm	3167.4		
G				444.5 cm	476.3		
H						68.6	64.8

MISC. SPECIFICATIONS:

BOOM ELEVATION: -4° to $+75^{\circ}$

TAIL SWING: 410.2 cm

OVERALL LENGTH - 10.1 - 24.4 m BOOM = 1254.8 cm
 10.4 - 31.7 m BOOM = 1286.5 cm

OVERALL HEIGHT - 29.5 x 25 TIRES = 365.8 cm
 26.5 x 25 TIRES = 334.0 cm

Grove RT-65s										
Wysięg R [m]	Długość wysięgnika [m]									
	10,00	11,60	13,40	15,20	17,10	18,90	20,70	22,60	24,20	33,90 (24,2+9,7)
3	30,00	30,00	28,89	26,31						
3,5	29,30	28,35	26,76	24,36	22,00	19,91				
4	26,54	26,04	24,72	22,45	20,82	19,64	16,56			
4,5	24,40	23,95	23,00	20,78	19,28	18,14	16,56	15,88		
5	22,50	22,18	21,46	19,37	17,92	16,83	15,97	15,15		
6	19,23	19,14	18,83	16,97	15,65	14,65	13,88	13,16	12,34	
7	16,24	15,42	15,20	15,11	13,84	12,93	12,20	11,57	10,93	
8	11,66	11,66	11,66	11,66	11,67	11,52	10,84	10,25	9,71	7,39
9		11,16	1,16	11,16	11,16	10,34	9,71	9,16	8,80	6,73
10			9,04	9,04	9,04	9,04	8,80	8,23	7,76	6,17
12				6,59	6,59	6,59	6,59	6,59	6,40	5,28
14					5,03	5,03	5,03	5,03	5,03	4,60
16						3,94	3,94	3,94	3,94	4,07
18							3,16	3,16	3,16	3,65
20								2,51	2,51	3,08
22									1,99	2,55
24										2,11
26										1,76
28										1,44
30										1,16
32										0,93

3. Tabele udźwigu